

Information

OpenScape Branch V2 Empowering the remote branch office

Leveraging the benefits of an open architecture in a Voice over IP enterprise communication environment, the OpenScape Branch is a SIP based server that dramatically empowers the remote branch offices.

Communication for the open minded

Siemens Enterprise Communications
www.siemens-enterprise.com/open

SIEMENS

Remote Branch Office

OpenScape Branch assures continued communication services while providing a feature rich set of survivability capabilities at a remote branch location during the loss or degradation of service between the remote branch and the main office.

OpenScape Branch is offered on several hardware platforms allowing a wide range of maximum user capacity: up to 50, 250, 1000 and 6000 registered lines.

All OpenScape Branch models include survivability features, Proxy, Media Server, Session Border Controller (SBC), and Branch SIP Trunking functionalities, while the OpenScape Branch 50i provides the additional functionality of integrated Analog Adapter and PSTN Gateway (GW).

The local Media Server supports tones, announcements and conferencing reducing the bandwidth needed to provide the same resources from a central location. This yields direct operational cost savings.

The Session Border Controller (SBC) provides security functions like Firewall and Virtual Private Network (VPN).

The OpenScape Branch is fully manageable via the Common Management Portal (CMP) as a single network element, making it an exceptional value.

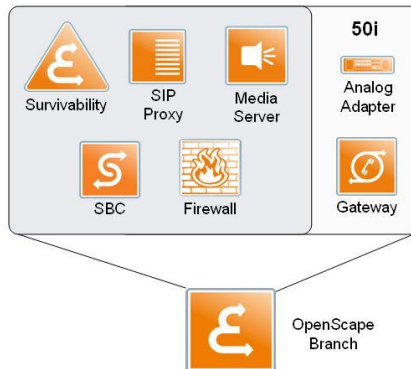

The OpenScape Branch has the flexibility to support, depending on the network topology, four deployment scenarios:

- Proxy,
- Proxy ACD
- SBC Proxy
- Branch SBC.

The OpenScape Branch is a fully RFC 3261 compliant SIP device and provides:

- Proxy – Registrar
- Call Routing functionality
- B2BUA functionality in Survivable mode
- Alternative Routing capabilities in case of Network outages

- TLS/TCP/UDP connections
- Local Announcement capabilities to reduce the WAN usage
- Full Management integration in OpenScape Voice management
- SBC functionality
- PSTN Gateway support
- Analog Adapter support
- Billing/CDR capabilities in Survivability mode
- OpenScape UC Geo-Redundancy support
- High serviceability for installation, upgrade and configuration

The OpenScape Branch provides a secure and reliable Branch configuration by supporting:

- VPN, IPSec
- State of the art Firewall with Layer 7 classification (SIP and MGCP awareness)
- Encrypted SIP signaling
- Encrypted management protocols
- VRRP like redundancy

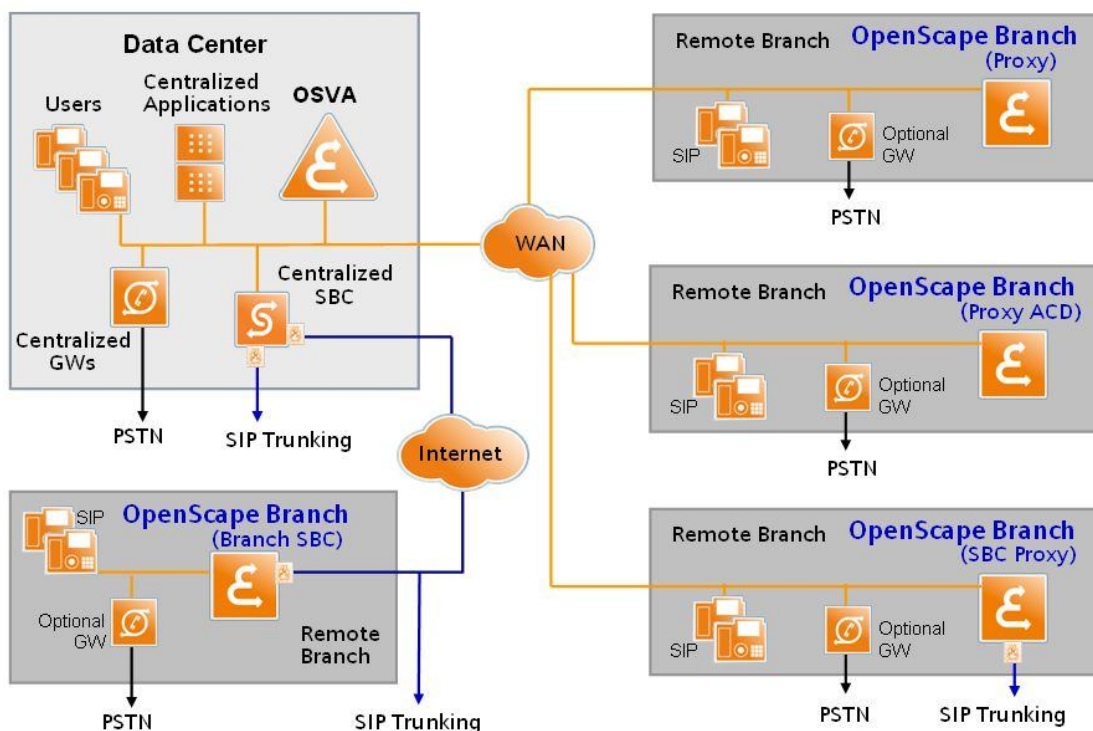

OpenScape Branch in the Network

Voice Features

Proxy

- SIP Proxy Server (RFC3261)
- SIP Registrar
- SIP Redirect/Routing Server
- SIP TLS
- OpenScape Voice controlled Media Server for Announcements and Conference

SBC

- SBC Header Manipulation for topology hiding
- SIP Session aware RTP Proxy for VoIP NAT support
- SBC trunk to SIP Service Providers

Media Server

- Media Server for Announcements, Tones and Conference

Survivability

- Multi Line Hunt Group support
- Call Forward and Call transfer
- Media Server for Tones, Announcements and Conference
- CDR creation, storage and transmission
- Basic Automatic Call Distribution (ACD)
- Digit manipulation
- Emergency call Support for multiple numbers based on subnet with LIN or CPM support
- Auto Attendant
- Backup Data Channel
- Multiple OpenScape Branch in a Branch
- Music on Hold

Security Features

Firewall

Stateful inspection Firewall NAT/PAT supporting:

- Intrusion detection

- Protocols DNS, SFTP, SSH, HTTPS, HTTP, NTP, SNMP
- Strict TCP Validation to ensure TCP session state enforcement, validation of sequence and acknowledgement numbers, rejection of bad TCP flag combinations
- TCP reassembly for fragmented packet protection
- Malformed packet protections
- Protocol anomaly protection

VPN

- IPSec
- Key generation is based on OpenSSL
- For message digest: MD2, MD5, MDC2, RMD-160, SHA, SHA-1, SHA-224, SHA-256, SHA-384, SHA-512
- For encoding and Cipher: Base64 Encoding, Blowfish, CAST, CAST5, DES, Triple-DES, IDEA, RC2, RC4, RC5

SIP Signaling

- TLS
- Key generation is based on OpenSSL
- For message digest: MD2, MD5, MDC2, RMD-160, SHA, SHA-1, SHA-224, SHA-256, SHA-384, SHA-512
- For encoding and Cipher: Base64 Encoding, Blowfish, CAST, CAST5, DES, Triple-DES, IDEA, RC2, RC4, RC5

Management

- SSH2, HTTPS, sFTP
- For PHP authentication CRIPT MD5 is used with a SALT of 12 chars

Management / Alarming Features

The OpenScape Branch supports the following Management Interfaces

- SOAP based OpenScape UC CMP/Assistant GUI
- Local PHP based WebGUI
- SW download via sFTP

- SNMP V2 support
- Continuous tracing OSV-TM
- Backup / Restore of configuration database
- SW installation
 - Full installation
 - Upgrade
 - Update
- Assistant Profiles

General Features

Routing

- Priority based routing
- Static Routes
- Source based routing
- VRRP like redundancy support
- SIP error code routing
- Auto Attendant

QoS / Traffic Control

- DSCP settings for Signaling, Media and Management traffic

Networking

- DHCP Server
- DNS Server/Client
- NTP Server/Client
- Support of Geo-Separated OpenScape Voice server deployment
- Local storage space for phone software redistribution

Logging

- Log data collection for all services
- Call trace data collection
- RapidStat collection

OpenScope Branch Models (without Integrated Gateway)

Performance	OpenScope Branch 50/ 250	OpenScope Branch 1000	OpenScope Branch 6000
Max. number of SIP registered lines *	250	1,000	6,000
Max. number of concurrent Sessions	50	200	2400
Max. number of call per second (continuous)	3	5	35
Max. Registrations per second (background)	10	20	40
Max. Registrations per second (peak)	250	1,000	6,000
Max. number of Announcement ports	7	16	50
Max. number of Conference ports	28	32	60
Max. number of SIP Trunks	1	10	10
Max. number of SIP Trunking Sessions	30	120	400
Max. number of Management Sessions	5	5	5

* Registered lines includes primary lines, secondary call appearances and phantom lines

OpenScope Branch 50/250



Based on Advantech SYS-2USM02-6M01E server.
 Physical Size (W x H x D): 300 x 65 x 300 mm (11.8"x2.6"x11.8")
 Weight: up to 4.5 Kg (9.9 lb)
 Power: 100~240 V AC , 50-60 Hz, 60W
 Heat Emission: 216.2 kJ/h (204.8 BTU)
 Operating Temperature: 0-40°C (32-104°F)
 Part Number : L30220-D600-A561

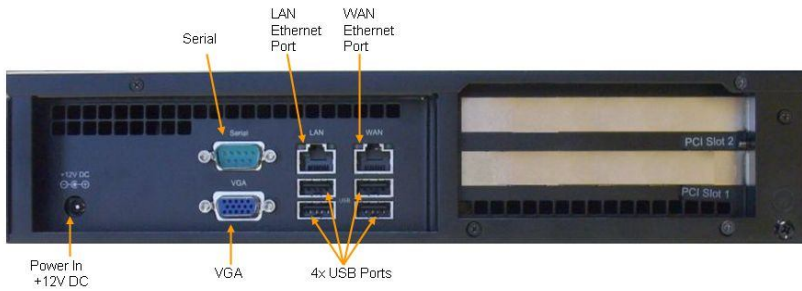

OpenScope Branch 1000



Based on the IBM x3250 M3 server
 Physical Size (W x H x D): 440 x 43 x 559mm (17.32"x 1.69"x 22.01")
 Weight: up to 12.7 Kg (28.0 lb)
 Power: 100~127/ 200~240 V AC , 50-60 Hz, 351W
 Heat Emission: 1263.7 kJ/h (1197.7 BTU)
 Operating Temperature: 10-35°C (50-95°F)
 Part Number : L30220-D600-A568

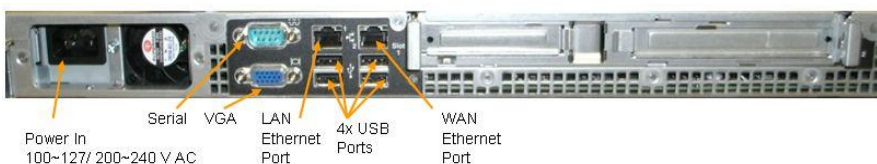

OpenScape Branch 6000

Offered on two platforms:



Based on IBM x3550 M3 server
Physical Size (W x H x D): 440 x 43 x 711 mm (17.32"x1.69"x27.99")
Weight: up to 15.4 Kg (34.0 lb)
Power: 100~127/ 200~240 V AC , 50-60 Hz, 351W
Heat Emission: 1263.7 kJ/h (1197.7 BTU)
Operating Temperature: 10-35°C (50-95°F)
Part Number : L30220-D600-A569

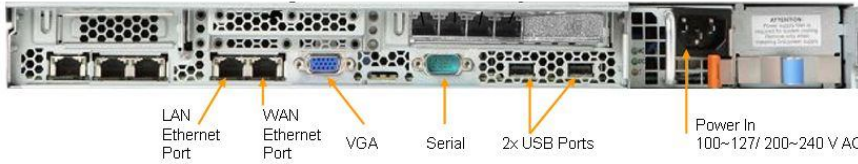

Based on Fujitsu Primergy RS200 S6 server.
Physical Size (W x H x D): 431 x 43 x 762 mm (16.97"x1.69"x30.00")
Weight: up to 17 Kg (37.5 lb)
Power: 100~127/ 200~240 V AC, 50-60 Hz, 549W
Heat Emission: 1976.4 kJ/h (1873.3 BTU)
Operating Temperature: 10-35°C (50-95°F)
Part Number : L30220-D600-A570

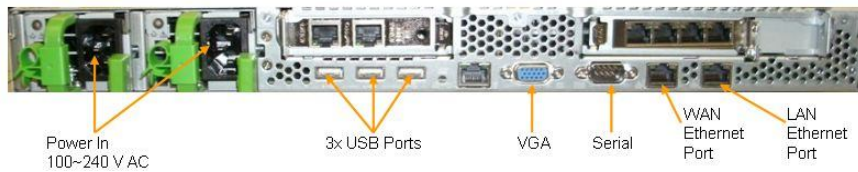

OpenScape Branch with Integrated PSTN Gateway

In addition to integrated Proxy, Survivability, Session Border Controller (SBC), SIP Trunking, and Media Server functionalities, the OpenScape Branch 50i also provides the additional functionality of Analog Adapter (AA) and PSTN Gateway (GW). It is available in the follows models:

- OpenScape Branch 50i A84 (8 FXO ports + 4 FXS ports)
- OpenScape Branch 50i D44 (4 BRI ports + 4 FXS ports)

- OpenScape Branch 50i DP14E (1 E1 PRI port + 4 FXS ports)
- OpenScape Branch 50i DP14T (1 T1 PRI port + 4 FXS ports)

This additional integration of Analog Adapter and PSTN Gateway functionality provides a better value as it requires smaller footprint and less power to operate. That results in direct operational savings and a greener solution.



Gateway

PSTN Interface (FXO)

- 8 RJ-11 connectors
- Trunk Type - Loop Start
- Nominal Impedance
- Software configurable AC and DC impedance to support most countries worldwide.
- Caller ID - FSK or country specific DTMF
- Ring Detection
- Answer (Loop supervision, Battery Reversal)
- Disconnect support (Loop supervision, country specific Busy detect)
- Software adjustable audio input and output level

Basic Rate Interface (BRI)

- 4 RJ-45 connectors
- Trunk support (EuroISDN)
 - ETS 300 012 - 1 (ITU-T I.430)
 - Layer 1,
 - ETS 300 402 – 1/2 (ITU-T Q.921) – Data Link Layer ,
 - ETS 300 403 – 1/2 (ITU-T Q.931) – Signaling Network Layer,
- ETS 300 102 – 1/2 (ITU-T Q.931) – Basic Call Control)

Primary Rate Interface (PRI)

- 1 RJ-45 connector
- Available with E1 or T1 Interface
- E1 Protocol support
 - EuroISDN
- T1 Protocol support
 - NI2

E1/T1 Interface

- Layer 1 - ETS 300 012 - 1 (ITU-T I.431)
- Layer 2 – ETS 300 402 – 1/2 (ITU-T Q.921) – Data Link
- Layer 3 – ETS 300 403 – 1/2 (ITU-T Q.931) – Signaling Network Layer
- Layer 3 – ETS 300 102 – 1/2 (ITU-T Q.931) – Basic Call Control

- Framing Types
 - Superframe (D4)
 - Channel Associated Signaling (CAS)
- Coding Types
 - Alternative Mark Inversion (AMI)
 - Bipolar with 8 Zeros Substitution (B8ZS)
 - High Density Bipolar of Order 3 Code (HDB3)
 - Optional Cyclic Redundancy Check 4 (CRC4)
- CAS E1 Protocol support
 - ITU-T Q.421
 - MFC-R2 - Brazil, Mexico
- Compliance
 - TBR 4, Net5

Analog Adapter

Interface (FXS)

- 4 RJ-11 connectors
- Trunk Type - Kewl Start
- Software configurable AC and DC impedance to support most countries worldwide.
- Ringer support of 3 REN (with Caller ID)
- Caller ID FSK or country specific DTMF
- Country specific tones support
- Software adjustable audio input and output level

Fax Support

Automatic selection between voice and fax

- Protocols (Group 3 Fax, Clear channel -G.711, T.38 Real Time)
- Fax Transmission (Up to 9600 kbps)
- DSP-based DTMF Tone Detection
- 16 Digit DTMF Decoding (0 to 9, *, #, A, B, C, D)
- RFC 2833 support (configurable)
- Echo cancellation up to 32ms

Performance

	OpenScape Branch 50i A84	OpenScape Branch 50i D44	OpenScape Branch 50i DP14E	OpenScape Branch 50i DP14T
Max. number of SIP registered lines *	50	50	50	50
Max. number of concurrent Sessions	40	40	40	40
Max. number of call per second (continuous)	1	1	1	1
Max. Registrations per second (background)	5	5	5	5
Max. Registrations per second (peak)	50	50	50	50
Max. num. of Announcement ports (concurrent)	4	4	4	4
Max. number of Conference ports (concurrent)	12	12	12	12
Max. number of SIP Trunking Sessions	20	20	20	20
Number of FXO ports	8	0	0	0
Number of BRI ports	0	4	0	0
Number of E1 PRI ports	0	0	1	0
Number of T1 PRI ports	0	0	0	1
Max. number of concurrent integrated GW calls	8	8	20	20
Number of Analog ports (FXS)	4	4	4	4
Max. number of Management Sessions	5	5	5	5

* Registered lines includes primary lines, secondary call appearances and phantom lines

OpenScape Branch 50i Models



Based on Advantech SYS-2USM02-6M01E server.
 Physical Size (W x H x D): 300 x 65 x 300 mm (11.8"x2.6"x11.8")
 Weight: up to 4.5 Kg (9.9 lb)
 Power: 100~240 V AC , 50-60 Hz, 60W
 Heat Emission: 216.2 kJ/h (204.8 BTU)
 Operating Temperature: 0-40°C (32-104°F)

OpenScape Branch 50i - A84

Analog - 8 ports FXO + 4 ports FXS (L30220-D600-A561)

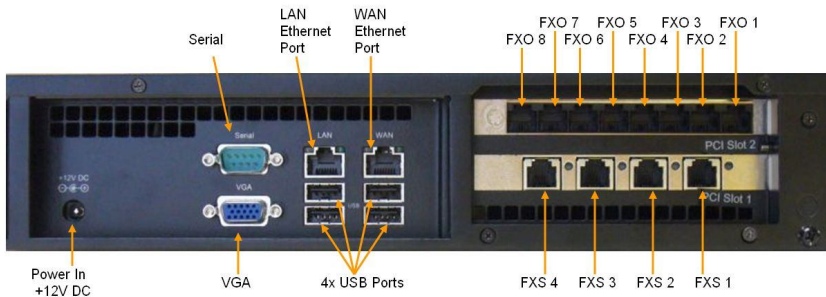

OpenScape Branch 50i - D44

Digital - 4 ports BRI + 4 ports FXS (L30220-D600-A562)

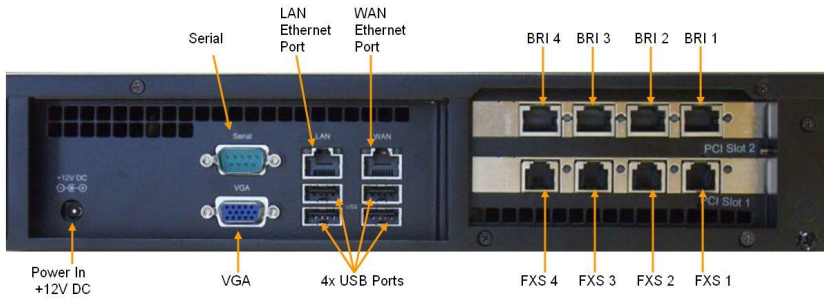

OpenScape Branch 50i – DP14E

Digital PRI - 1 port E1 PRI + 4 ports FXS (L30220-D600-A563)

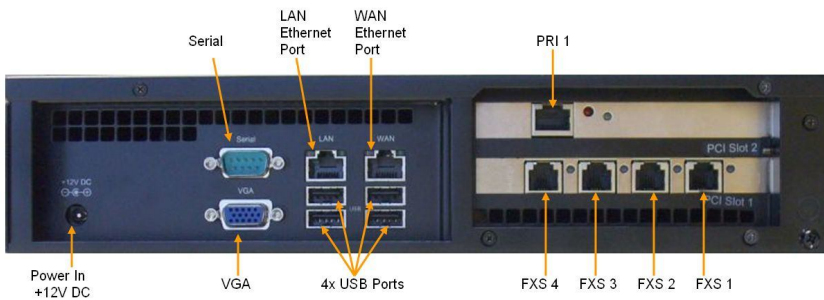

OpenScape Branch 50i – DP14T

Digital PRI - 1 port T1 PRI + 4 ports FXS (L30220-D600-A564)

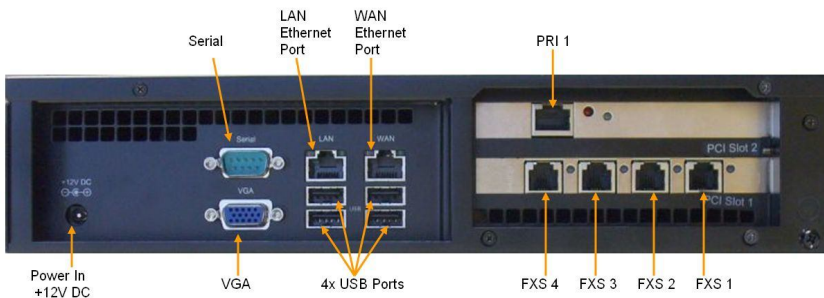

Copyright © Siemens Enterprise
Communications GmbH & Co. KG 10/2011
Hofmannstr. 51, D-80200 München,

**Siemens Enterprise Communications GmbH & Co. KG
is a Trademark Licensee of Siemens AG**

Reference No.: A31002-H8121-D100-1-7629

The information provided in this document contains merely general descriptions or characteristics of performance which in case of actual use do not always apply as described or which may change as a result of further development of the products. An obligation to provide the respective characteristics shall only exist if expressly agreed in the terms of contract. Availability and technical specifications are subject to change without notice.

OpenScape, OpenStage and HiPath are registered trademarks of Siemens Enterprise Communications GmbH & Co. KG. All other company, brand, product and service names are trademarks or registered trademarks of their respective holders.